

LOVOL FR36F-u EXCAVATOR



SIDE VIEW – ZERO SWING

FLEXIBILITY

- TAILLESS DESIGN
- TURNING RADIUS 850MM
- BOOM SIDE SHIFT
- SMALL PIECE CORNER OPERATION

RELIABILITY

- IMPORTED ENGINE, STRONG PERFORMANCE, HIGH QUALITY, LOW NOISE DESIGN
- ELECTRONICALLY CONTROLLED POWER CONTROL, MORE POWER, STRONGER, MORE FUEL CONSUMPTION

ENGINE

EFFICIENCY

- BOOM BUCKET ROD ASSEMBLY EXPLOSION – PROFF VALVE
- PREVENT FAILING, OIL SPRAY
- LOAD SENSITIVE FLOW CONTROL
- ALLOCATE THE APPROPRIATE FLOW ACCORDING TO THE DEMAND OF THE LOAD
- LARGE WORKING RANGE
- MAXIMUM EXCAVATION RADIUS 5225MM
- PRECISE DISTRIBUTION
- THE RIGHT FLOW RATE CAN BE ALLOCATED ACCORDING TO THE DEMAND OF THE LOAD
- LARGE BUCKET CAPACITY
- BUCKET CAPACITY 0.12M³, HIGH WORKING EFFICIENCY



REMOTES

COMFORT

- HUMANIZED DESIGN
- INCREASE THE WATER CUP HOLDER, INCREASE THE CONTROL BUCKET COMFORTABLE OPERATION
- INCREASED BUCKET HEIGHT AND REVERSABLE BACKREST
- NEW APPEARANCE DESIGN, PROPORTION COORDINATION, HIGH END ATMOSPHERE
- BACKREST CAN BE TURNED OVER, BACKREST CUSHION HARNESS CAN BE ADJUSTED
- NEW INTERIOR LAYOUT, ERGONOMIC, ENHANCED DRIVING CONFORT
- INTELLIGENT TBOX ADD ETHERNET – CAN ACHIEVE REMOTE ATO

CHAIR

SAFETY

- CAB MEETS CERTIFICATION REQUIRMENTS
- CAB MEETS FOPS/TOPS STANDARDS AND CE CERTIFICATION
- GOOD STABILITY
- CHASSIS 1700MM
- TYPE-C/USB CHARGING POINT. RELIABLE, EASY ACCESS TO ELECTRICITY
- THREE LEVEL MAINTENANCE FILTER ELEMENT IS ADAPTED TO EFFECTIVELY PROTECT THE ENGINE AND EXTEND THE SERVICE LIFE
- THE STANDARD THREE-WAY BALL VALVE ENABLES EASY SWITCHING BETWEEN FITTINGS AND PIPELINES

CAB

TECHNICAL SPECIFICATIONS

ENGINE

ENGINE MODEL	YAMNAR 3TNV88F
NUMBER OF CYLINDERS	3
MAX. TORQUE/SPEED	103/1600N- M/PH
DISPLACEMENT	1.62L

MAIN PERFORMANCE

BUCKET DIGGING FORCE	30kN
ARM DIGGING FORCE	19kN
MAX. TRACTION FORCE	35.1kN
MAX. WALKING SPEED	4.2KM/H
MIN. WALKING SPEED	2.7KM/H
ROTARY SPEED	8.4R/MIN
GRADEABILITY	30°
GROUND PRESSURE	34.7kPa

HYDRAULIC SYSTEM

MAX. MAIN PUMP FLOW	108L/MIN
MAIN SAFETY VALVE PRESSURE	24.2MPA

OIL CAPACITY

FUEL TANK	40L
HAYDRAULIC TANK	20L
ENGINE OIL	6.7L

INSIDE CAB

BUCKETS AVAILABLE IN OTHER SIZES

AUGER

GRAPLE

TRAILER

STANDARD QUICK HITCH

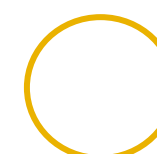
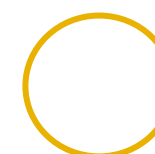
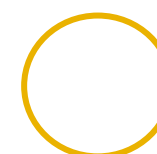
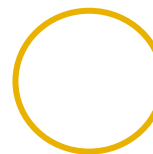

TANNERTRACK
TRACTORS AND EQUIPMENT

15 INNOVATION WAY,
PAKENHAM 3810
PH: 1300 144 988
PH: 03 5922 4505
sales@tannertrack.com.au
tannertrack.com.au

STANDARD CONFIGURATIONS

ENGINE

- TURBOCHARGED 4 STROKE WATER-COOLING
- ELECTRONIC INJECTION TYPE
- COMPLYING WITH CHINA STAGE III EMISSIONS
- AUTOMATIC IDLE SYSTEM
- ENGINE OIL PAN DRAIN VALVE
- RADIATOR WITH PROTECTIVE NET
- DOUBLE FILTER ELEMENT DRY AIR FILTER ELEMENT
- AIR PRE-FILTER
- AIR INTAKE HEATER
- FAN GUARD

HYDRAULIC SYSTEM

- AUTOMATIC HYDRAULIC SYSTEM (CONFLUENCE SYSTEM)
- BOOM & ARM BLOCK VALVE
- ANTI-SWING VALVE
- MULTI-STAGE FILTRATION SYSTEM
- CYLINDER BUFFER DEVICE
- AUXILIARY HYDRAULIC VALVE
- AUTOMATIC TWO-SPEED TRAVEL MOTOR

ELECTRONIC CONTROL SYSTEM

- 24V POWER SUPPLY
- DIAGNOSTIC INTERFACE
- EMERGENCY STOP WATCH
- DISPLAY BRIGHTNESS ADJUSTMENT
- MAINTENANCE TIPS
- AUTOMATIC DIAGNOSTIC SYSTEM
- AUTOMATIC IDLE SYSTEM
- ONE-TOUCH PRESSURE AUGMENTATION
- SAFE STOP / START FUNCTION
- MAIN POWER SWITCH
- ANTI-THEFT SYSTEM
- ENGINE STARTING PROTECTION
- MULTILINGUAL DISPLAY

TECHNICAL SPECIFICATIONS

CAB

- SEATBELT
- FRONT SUNSHADE
- STORAGE BOX
- ESCAPE HAMMER
- THERMOSTATICALLY CONTROLLED AIR CONDITIONER
- SHOCK ABSORBER (SILICONE OIL AND RUBBER PAD)
- FLEXIBLE ANTENNA
- RADIO WITH INTERFACES OF MP3 AND USB
- HYDRAULIC SAFETY LOCK
- SUN PROTECTION SAFETY GLASS
- FLOOR MAT
- LARGE STORAGE AREA
- PULL-UP FRONT WINDOW
- REMOVABLE LOWER WINDSHIELD
- SUNSHADE WINDOW
- FRONT-BOTTOM GLASS PROTECTIVE SCREENING
- WIPERS
- OPEN SKYLIGHT
- ASHTRAY
- CIGARETTE LIGHTER

SWING PLATFORM

- PASSAGE WITH RAILING
- TOOL BOX
- ANTI-SKID PLATE
- LARGE PEDAL
- LARGE ARMREST
- BOTTOM PROTECTION PLATE
- ANTI-COLLISION BEAM

CHASSIS

- FIXED CHASSIS
- 300MM THREE TOOTH TRACK SHOE

TANNERTRACK

TRACTORS AND EQUIPMENT

15 INNOVATION WAY,
PAKENHAM 3810
PH: 1300 144 988
PH: 03 5922 4505
sales@tannertrack.com.au
tannertrack.com.au

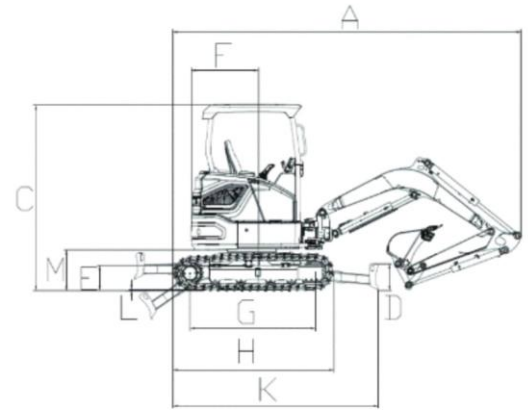
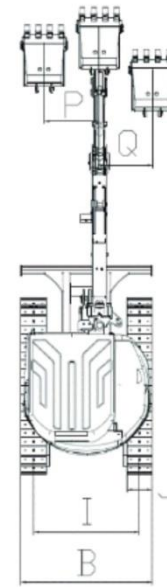

TECHNICAL SPECIFICATIONS

WORKING RANGE

MAX. DIGGING HEIGHT	1	4840MM
MAX. DUMPING HEIGHT	2	3425MM
MAX. DIGGING DEPTH	3	2890MM
MAX. VERTICAL DIGGING DEPTH	4	2580MM
MAX. DIGGING RADIUS	5	5225MM
MAX. GROUND DIGGING RADIUS	6	5105MM
MIN. TURNING RADIUS	7	/

TECHNICAL SPECIFICATIONS

DIMENSIONS

SHIPPING LENGTH	A	4730MM
SHIPPING WIDTH	B	1700MM
BOOM HEIGHT	C	2470MM
DOXER BLADE HEIGHT	D	348MM
MIN. GROUND CLEARANCE	E	300MM
TAIL TURNING RADIUS	F	850MM
LENGTH TO CENTRE OF ROLLERS	G	1620MM
TRACK LENGTH	H	2094MM
TRACK GAUGE	I	1400MM
TRACK SHOE WIDTH	J	300MM
SHIPPING GROUND LENGTH	K	2614MM
TRACK PLATE HEIGHT	L	15MM
GROUND CLEARANCE OF COUNTER WEIGHT	M	537MM

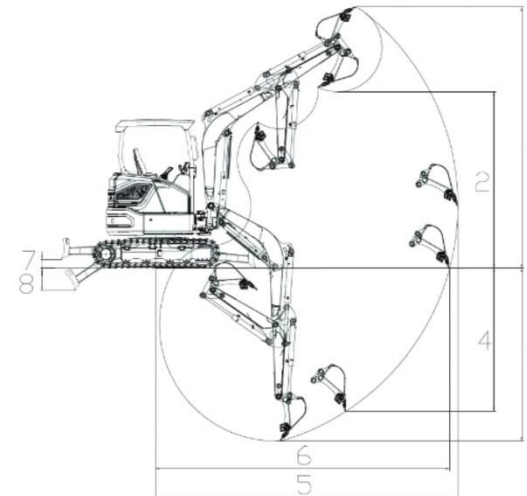

QUICK HITCH

TAIL SWING

SWING BOOM ON SIDE

DIMENSIONS

BOOM LENGTH	2375MM
ARM LENGTH	1325MM
TRACK SELECTION NUMBER - EACH SIDE	43
TRACK ROLLER NUMBER	4

LOVOL

FR36F-u EXCAVATOR